

SYNCRO

More than just control

Do you **SYNCRO** your process?

SYNCRO is the ideal partner for plastics processors who require innovative technology to gain a competitive edge. We provide reliable process control products, paired with fast service and support.

Based in Italy, SYNCRO has four branch offices throughout Europe, Asia, and South America. Joint ventures have been established in North America, Latin America, and Asia.

Our rapid growth is attributed to our professional team members “The SYNCRO Family” who design flexible solutions to meet our customer’s needs.

At SYNCRO, our success is based on your success!



The World **SYNCRON**ized



SYNCRON U.S.A.

SYNCRON service
SWEDEN 🇸🇪

SYNCRON
HEAD QUARTER

SYNCRON service
SPAIN 🇪🇸

PLUS

SYNCRON service
EL SALVADOR 🇸🇻

SYNCRON latina

SYNCRON
SYNCRON srl

Viale dell'Industria, 42
21052 Busto Arsizio (VA)
Phone +39.0331.677716
Fax +39.0331.326581
Web www.syncro-group.it
E-mail info@syncro-group.it

PLUS
PLUS srl

Via Braccasca, 80
48100 Ravenna - Italy
Phone +39.0544.270335
Fax +39.0544.271498
Web www.plusmarine.com
E-mail info@plusitaly.eu

SYNCRON U.S.A.
SYNCRON USA, LLC

40329 GOLDENROD Ln,
WADSWORTH, IL 60083
Phone +1.888-778-9804
Fax +1.847-556-6099
Web www.syncrousa.net
E-mail sales@syncrousa.net

SYNCRON latina
SYNCRON LATINA

Rua do Tramway 322, ap. 62
Para Inglesa c.p. 02303-080
São Paulo - Brasil
Phone +55.11.29966653
E-mail latina@syncro-group.it

syncro-group.it



SHINI-SYNCR0 extrusion control, LTD China

Dalang, Dongguan,
Guangdong - China
Phone +86.769.8267.7669
Fax +86.769.8267.7663
E-mail dongguan@shini-syncro.com

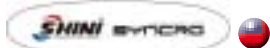

SHINI-SYNCR0 extrusion control, LTD Taiwan

Minhe Street, Shulin City,
Taipei, Taiwan
Phone +886.2.2680.9119
Fax +886.2.2680.9229
E-mail taipei@shini-syncro.com



SHINI-SYNCR0 extrusion control, LTD India

Village: Waliv Tal. Vassai,
Dist: Thane, India
Phone +91.96.2345 2250
Fax +91.96.2345 2257
E-mail india@shini-syncro.com



JR Servicio Tecnico

C/Livia, n°7
08748 Cervellò - Barcelona
Phone +34.609.751935
E-mail josep@syncro-group.it



SKÅNSK ELTEKNIK AB

Hammarvägen 1
ARLÖV - SVERIGE23237
Phone +46.40.432266
Fax +46.40.430308
E-mail anders@syncro-group.it



PS Plastic Services Latin America

Km 31, Carretera a Sonsonate,
Sacacoyo, La Libertad El Salvador
Phone +503.71296719
E-mail juanjose@syncro-group.it



flyer AUTO, is the new SYNCRO PATENT PENDING automatic air ring designed for high efficiency and high output. Elevators lift up the automatic upper four lip air ring almost doubling the line throughput while improving physical proprieties of the film as per tear, haze, elongation and especially dart drop.

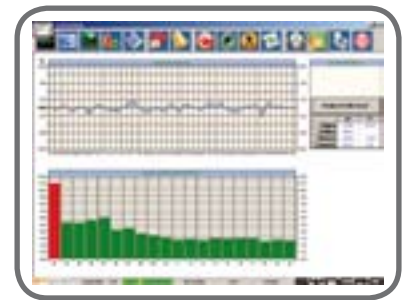
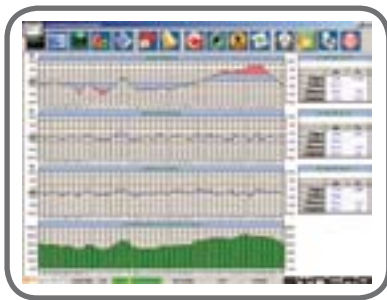

		Tradizional Air Ring	FLYer	Range of Values
Die diameter	mm	350	350	
2° air ring diameter (Virtual die)	mm		445	
Ratio die / Virtual die	-		1,27	(1,15-1,30)
Film thickness	µm	70	70	
Lay Flat	mm	1905	1905	
BUR 1 (Bubble diam / 2° Air ring)	-		2,73	(1,7-3,0)
BUR 2 (Bubble diam / Die diam)	-	3,47	3,47	(3,5-5,0)

Type of material	K kg / (h mmØ)	Output (kg / h)	Output (kg / h)	K kg / (h mmØ)	Output/Output %
100% LDPE	1,05	367	734	2,10	200,2
50% LLDPE (C6-C8) + 50% LDPE	0,91	319	639	1,83	200,2
75% LLDPE (C6-C8) + 25% LDPE	0,87	304	609	1,74	200,2
100% LLDPE (C6-C8)	0,78	271	543	1,55	200,2
100% LPDE (C4)	0,77	268	536	1,53	200,2

When **flyer** is raised to the upper position where the bubble expansion is greater, it provides efficient cooling over a larger surface. Simple start-up and die cleaning are added benefits of the vertical adjustment. **flyer** AUTO provides segmented airflow to localized areas around the blown film bubble through the air ring while stabilizing the film exit due to the forth special downward **flyer** lip. This automatic thickness improvement system offers simplicity and state-of-the-art visualization giving the highest operational reliability. The system effectively increases the low areas in the film to improve quality and yield.

duplex , is the new SYNCRO stacked automatic air ring for high efficiency and high output. Elevators lift up the automatic upper three lip air ring to increase the line throughput almost doubling the output while improving physical properties of film as per tear, haze, elongation and especially dart drop.

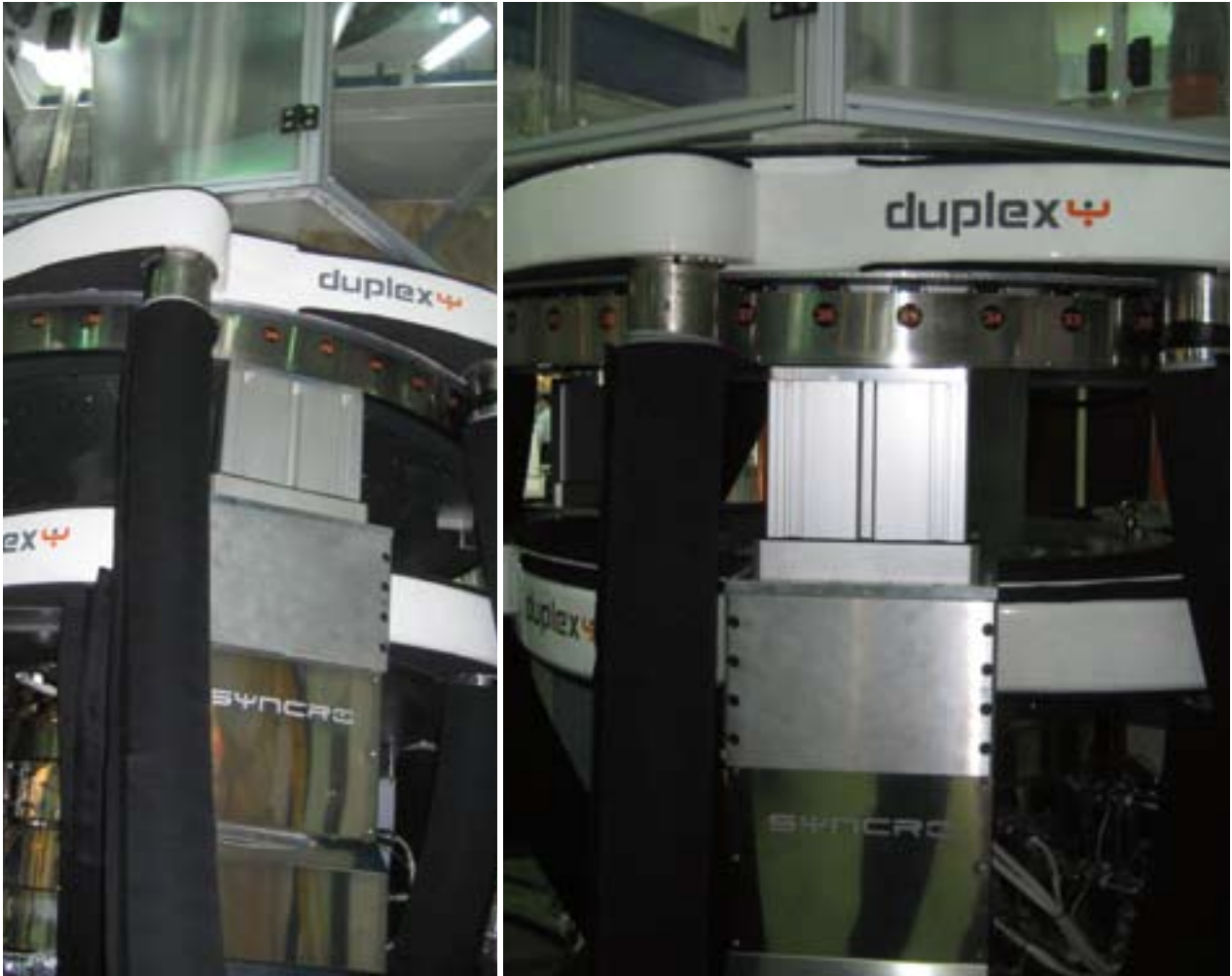

When **duplex ** is raised up to the upper position where the bubble expansion is greater so cooling becomes more efficient over a larger surface. **duplex ** provides segmented airflow to localized areas around the blown film bubble through the air ring, while stabilizing the film exit due a lower single lip air ring.

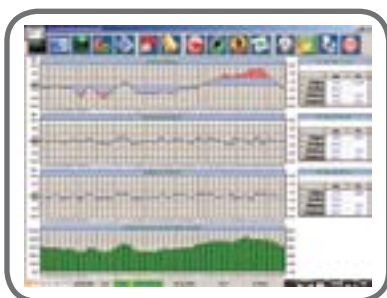



Sypro AUTO is a completely automatic system for the on-line thickness profile control. The air flows of the segmented disk integrated into the air ring are controlled by stepper motors which adjust the opening/closing of the gates.



The thickness measuring system is integrated into the supervision software and supplies **Sypro AUTO** with the measured profiles.

When measuring a point having a thickness higher than the set tolerance, the stepper motor will decrease the air flow into the corresponding segment, thus reducing the film thickness, while, when measuring a point with a thickness lower than the tolerance, the air flow is increased in order to increment the thickness.



eaSYflow is our Patented dual lip cooling air ring which offers a fine adjustment of air volume to control the lip set.

Characteristics:

- ✦ Upgradable to automatic control in the future
- ✦ Adjustable lips
- ✦ Adjustable forming cone
- ✦ 6/8 air inlets
- ✦ Interchangeable lip-set
- ✦ Aluminium casting construction

 syncro-products.it/easyflow



SYpro MAN

SYpro MAN is the easiest and least expensive control system for the profile: by simply integrating a segmented disk with the standard air ring, it is possible to manually adjust the air flow in the different segments thanks to dedicated screws/gates.

The operator, after checking the film thickness off-line, can adjust the opening of every single gap of the segmented disk and regulate the air flows, thanks to which the profile is regulated. It is particularly suitable for those installations which do not require a frequent production change.

 syncro-products.it/syproman



opt+mex, patent NON CONTACT gauging system based on NIR reflex technology for blown film. **opt+mex** provides a continuous measuring of material thickness. Installed on an oscillating ring it is able to refresh the profile every 2-3 minutes, uninfluenced by the haul off speed.

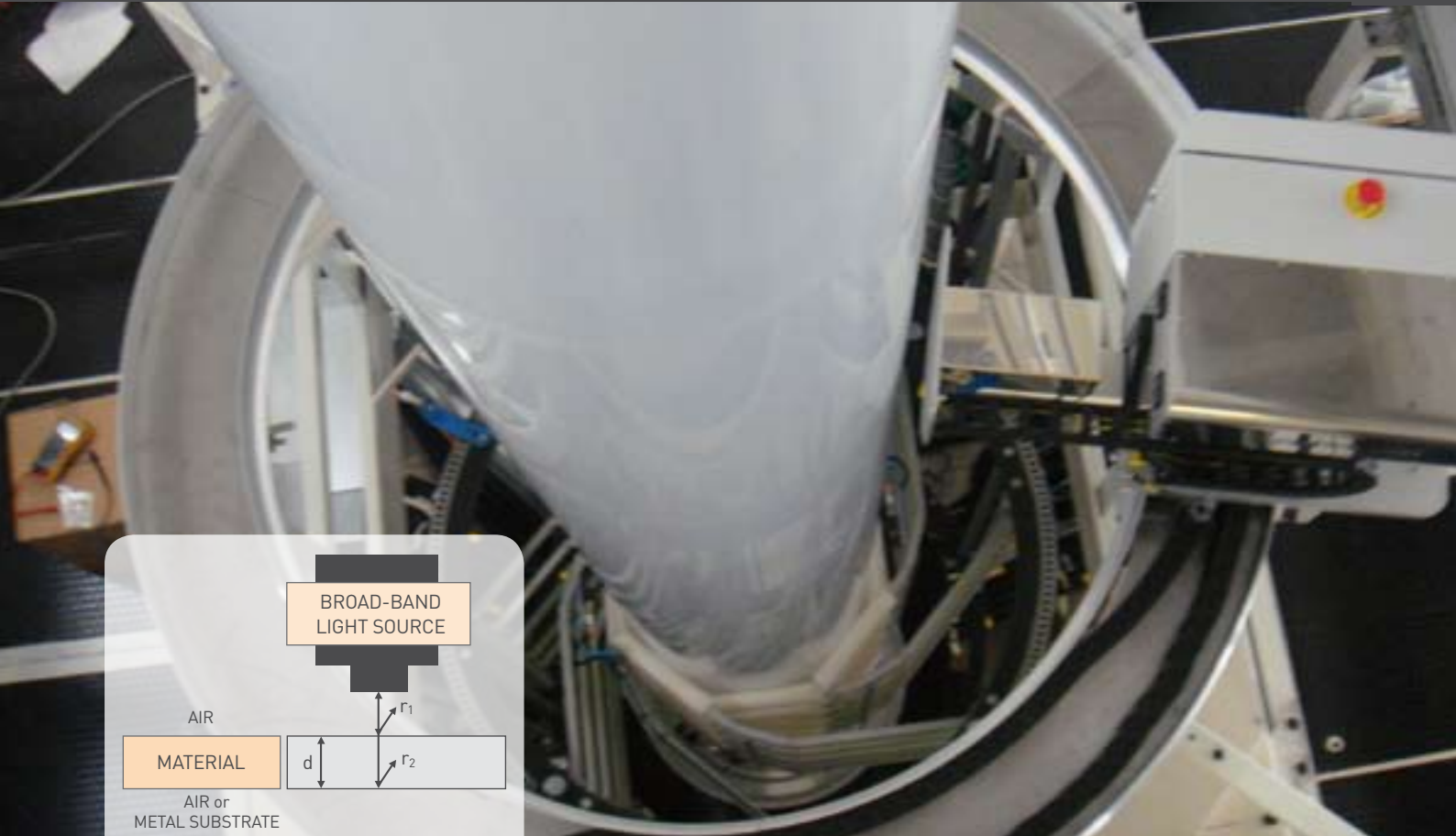

The sensor can be used to measure total thickness of materials for which the component r_2 has sufficient optical intensity to provide the interference signal, transparent or semi-transparent materials. Colored material can also be measured under certain conditions. It is also possible to measure materials on metal substrates because the metal base is reflective.

Utilizing modular  technology, **opt+mex** ensures simple, practical operation by providing the operator with all the information required to operate the system clearly and intuitively using a touch screen HMI.

SYNCRO **combYscan**, patented measuring system based on non-contact inductive/capacitive technology. The new sensor combY is composed by an Inductive/capacitive sensor which allows the measurement of either sheet and/or film's thickness using a cylinder as a contrast.



CombY uses the inductive technology to measure the distance between sensor, cylinder feedback and one second capacitive sensor which, pending measurement of dielectric material, provides a more accurate thickness value.

For a blown film line **combYscan** can be installed after the haul-off and the SYNCRO patented software will be able to measure the flattened film and calculate the profile quickly, prior to a complete rotation of the haul-off.

Utilizing modular PLC  technology, **combYscan** ensures simple, practical operation by providing the operator with all the information required to operate the system clearly and intuitively using a touch screen HMI.

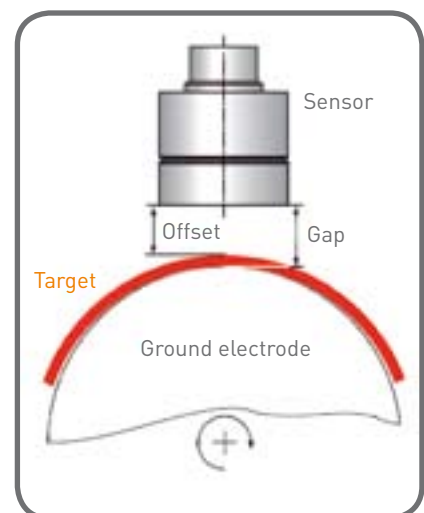



eaS^ymex is based on capacitive technology and provides a continuous thickness measurement. It can be installed either stand alone on the collapsing frame or on an oscillating ring connected to an auto profile control. **eaS^ymex** is available in either contact or NON contact versions for materials considered sticky and/or delicate.

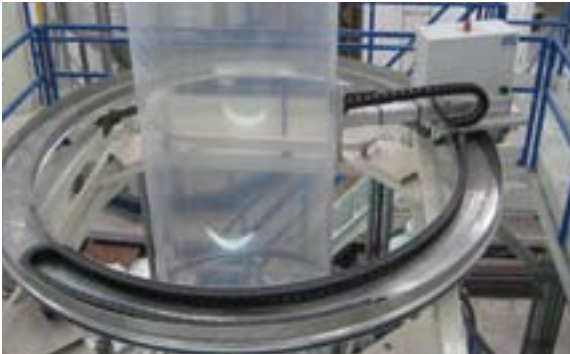

eaS^ymex
NON CONTACT



Utilizing modular  technology, **eaS^ymex** ensures simple, practical operation by providing the operator with all the information required to operate the system clearly and intuitively using a touch screen HMI.

S^yhead

S^yhead is based on inductive NON contact technology. It is installed after the haul-off unit and measures the thickness of one edge of the flat film, thus obtaining the complete profile whenever the take-off unit oscillates 360°.



syncro-products.it/syhead



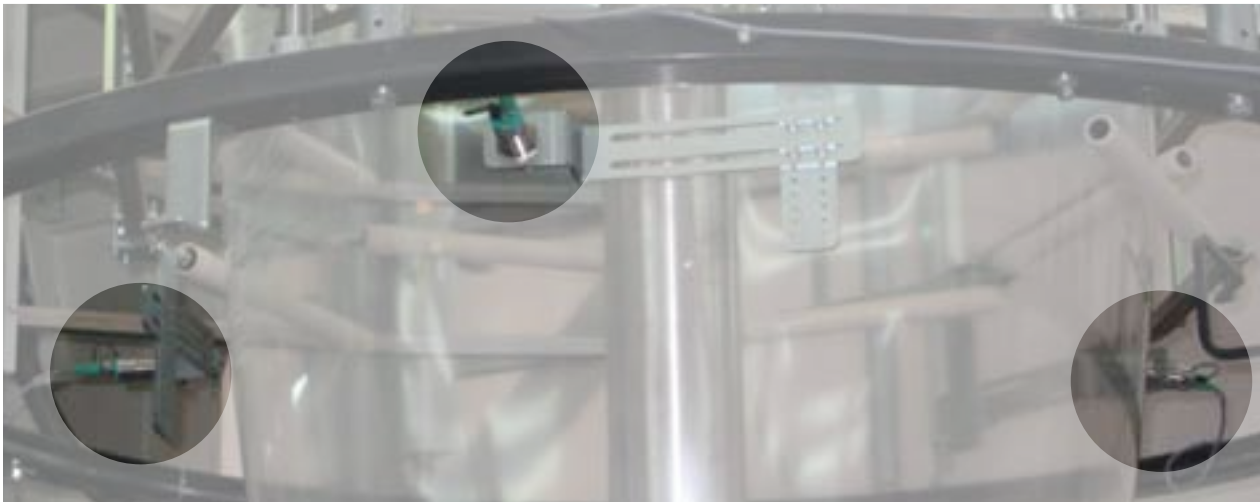

Bubble stability control

SYIBC is designed to automatically control and manage blower balance while coordinating all blower control functions. **SYIBC** is equipped with an ultrasonic distance sensor to be installed on the bottom part of the cage on the movable arms to keep the gap constant between sensor and bubble. Optional additional ultrasonic distance sensors can be installed above the cage where the bubble is already formed to

control lay flat and automatic opening/closing of the cage. The customized control valve provides the fine tuning necessary for high precision and accuracy in bubble stability and lay flat control. Utilizing modular  technology, **SYIBC** ensures simple, practical operation by providing the operator with all the information required to operate the system clearly and intuitively using a touch screen.

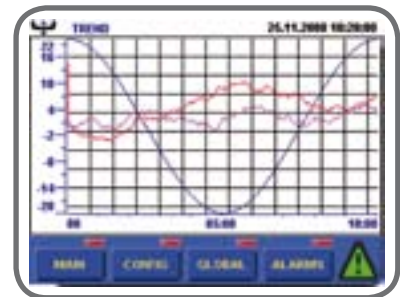
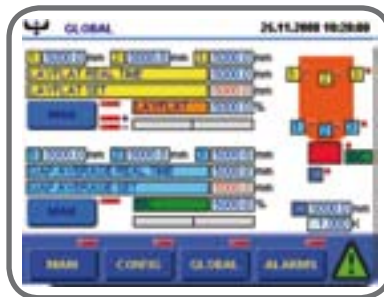

Lay flat control



Fine tuning valve



Patented by SYNCRO, **optyscan** represents the latest film measuring technology on the market.

Main advantages versus current competing technology:

- ✦ NIR technology, based on interferometer concept avoiding any bureaucratic procedure.
- ✦ Optical technology has a small, 1 mm measuring area, much more accurate than IR, X-ray or Beta-ray whose measuring area can be higher than 10 mm.
- ✦ Optical is backscatter so it doesn't require a receiver.
- ✦ Optical doesn't care if film is moving up and down or of any particularly vibration, quality of measure will be kept the same.
- ✦ Thanks to the unique installation on the chill roll, optyscan will guarantee a faster response in auto profile control due to its proximity to the die. This is important during start-up where each meter of film extruded is important.



Actual Data		Target Data	
SPD 01	175.000	175.000	0
SPD 02	150.000	150.000	0
SPD 03	1500.000	1500.000	0
SPD 04	1500.000	1500.000	0
SPD 05	1500.000	1500.000	0
SPD 06	1500.000	1500.000	0
SPD 07	1500.000	1500.000	0
SPD 08	1500.000	1500.000	0
SPD 09	1500.000	1500.000	0
SPD 10	1500.000	1500.000	0
SPD 11	1500.000	1500.000	0
SPD 12	1500.000	1500.000	0
SPD 13	1500.000	1500.000	0
SPD 14	1500.000	1500.000	0
SPD 15	1500.000	1500.000	0
SPD 16	1500.000	1500.000	0
SPD 17	1500.000	1500.000	0
SPD 18	1500.000	1500.000	0
SPD 19	1500.000	1500.000	0
SPD 20	1500.000	1500.000	0





The optical sensor is based on low coherence interferometry. The material is illuminated with a broadband near-infrared light source; part of this light is reflected at the air/material interface (component r1).

Part of the light that travels through the material is then reflected in correspondence of the material/air boundary (component r2).

The optical head collects both r1 and r2 and disseminates information between the two components.

The resulting optical signal intensity has an oscillatory component with a frequency f , called optical thickness, given by $f = 2nd$, where d is the thickness and n is the refractive index of the material.

Measuring f and knowing n , the thickness d can be obtained with high accuracy.

TECHNICAL SPECIFICATION	VERSION		
	EP1	EP2	EP3
Max thickness (1)	100µm	380µm	1800µm
Opical source	Halogen Lamp	SLD	
Accuracy (2)	← 0,1 micron		
Measuring time (3)	← 10 ms		
Spot dimension	~ 3 mm	~ 1 mm	
Working range	30-50 mm	35-45 mm	

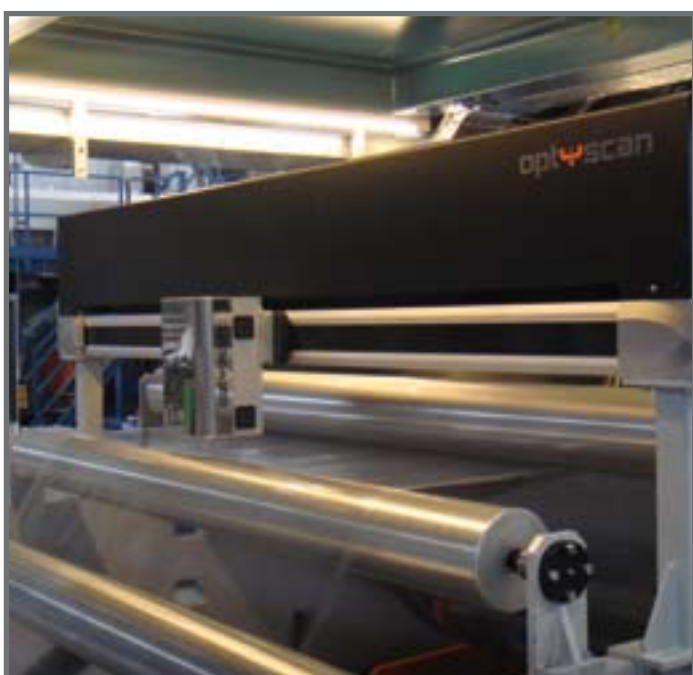
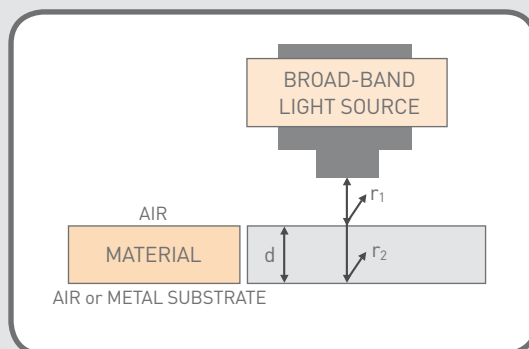

The sensor can be used to measure total thickness of materials for which the component r2 has sufficient optical intensity to provide the interference signal, like transparent or semi-transparent materials; colored material can also be measured under certain conditions.

It is also possible to measure materials on metal substrates because the metal base is reflective.



SYscan A is a member of the SYNCRO family of measuring systems. **SYscan A** is composed of a mechanical scanner suitable to measure film of different widths and is complete with microprocessor electronics with Ethernet network interface.



SYscan A is based upon a largely used working principle, such as the inductive measuring system of the distance. **SYscan A** is composed by two measuring heads which are equipped with compressed air nozzles with a particular patented

geometry, which produces an air cushion having a constant thickness between heads and film so as to allow the film/sheet movement without the contact of the heads and without marking the extruded product.

rayxcan



SYNCRO **rayxcan**, is a revolutionary new gauge which measure the thickness and weight of foils, sheets, films of any type of material without



radiation. The X-ray backscatter sensor raYx is based on the measurement of Compton rays, scattered by the material being measured. Compton rays are very similar to beta rays in that their absorption is relatively insensitive from chemical composition.

They have the great advantage to be generated from a tube and do not suffer therefore the costs and the limitations due to the use of radiation. In addition the raYx is mounted on a single sided traversing frame and it offers advantages of cost and space.

SYNTROLgauge is the SYNCRO auto die system to control automatically the thermal cartridge in the flat die to regulate the film/sheet thickness being able to modify mechanically the flat die lip.

Due to the smart control special die mapping will allow the system to consider material neck-in, neck-out and bumping to achieve a better auto die control to get always the best product.

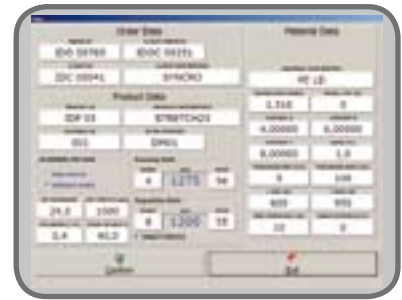

SYNTROLgauge auto profile control meets application also on blown film line process.

It can be interfaced on OEM die with thermal cartridge heaters to modify the die lip opening/closing according to the target thickness.

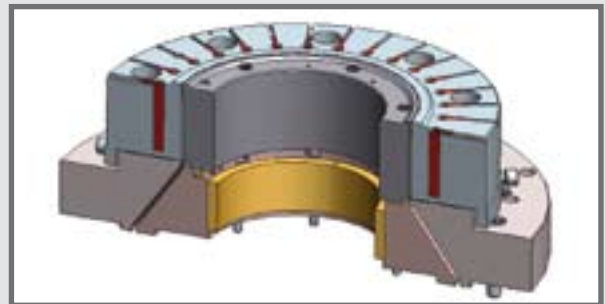

It can also be interfaced to auto air ring with cartridge heaters internally installed where according to the profile set the air temperature will be modified accordingly.



Based on commercial modular PLC  electronics, **SYNTROLgauge** ensures simple, practical operation by providing the operator with all the information required to operate the system clearly and intuitively using touch screen HMI on board. In blown film application **SYNTROLgauge** would be controlled and connected to any of the SYNCRO gauging system for blown film line.

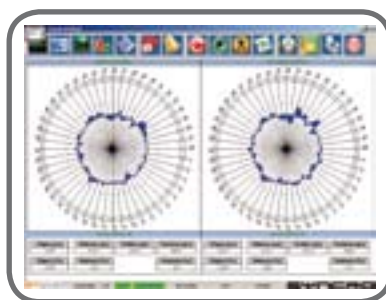



SYblend is a continuous loss in weight gravimetric blender designed to blend multiple components simultaneously for all processes where a homogeneous mix is critical to achieving an excellent final product.

SYblend meets all need of high demanding process as per BCF, FDY and POY.

Each hopper and material is weighed by two off-center load cells.



Based on commercial modular PLC electronics, **SYblend** ensures simple, practical operation by providing the operator with all the information required to operate the system clearly and intuitively using touch screen HMI on board.





Process control software **SYblend**:

- Loss in weight control
- Gram/metre and throughput control
- Materials consumption
- Alarms

Sydos is a continuous loss in weight gravimetric dosing system designed to dose and feed multiple components simultaneously in all processes in which a constant gravimetric feeding is required. Each hopper and material is weighed by two off-center load cells.

Utilizing modular PLC  technology, **Sydos** ensures simple, practical operation by providing the operator with all the information required to operate the system clearly and intuitively using a touch screen HMI.

Process control software **Sydos**:

-  Loss in weight control
-  Gram/metre and throughput control
-  Material consumption
-  Alarms

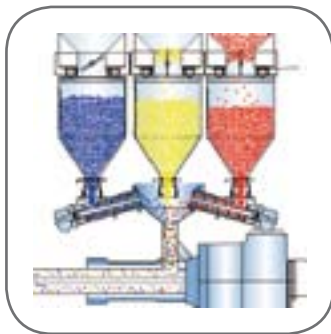







SYbatch is the revolutionary and patented loss in weight gravimetric batch blender designed to dose and blend multiple components simultaneously in all processes in which a constant gravimetric feeding and a homogeneous mix is required.



Innovative logic and design make **SYbatch** a unique system solving most of the problems with classic gain in weight batch blender technology.

Utilizing modular PLC  technology, **SYbatch** ensures simple, practical operation by providing the operator with all the information required to operate the system clearly and intuitively using a touch screen HMI.

Process control software **SYbatch**:

-  Loss in weight control
-  Gram/meter and throughput control
-  Material consumption
-  Alarms

eaSΨbatch is the traditional gain-in-weight batch blender, designed to dose and blend multiple components in sequence for all processes where constant gravimetric feeding and a homogeneous mix is required.



Utilizing modular PLC  technology **eaSΨbatch** ensures simple, practical operation by providing the operator with all the information required to operate the system clearly and intuitively using a touch screen HMI.

Process control software **eaSΨbatch**:

- Ψ Loss in weight control
- Ψ Gram/meter and throughput control
- Ψ Material consumption
- Ψ Alarms



SYline is a gravimetric loss in weight hopper designed to gravimetrically feed the extruder throat controlling the throughput set.

The weight hopper and relative material is weighted by two off-centre load cell.

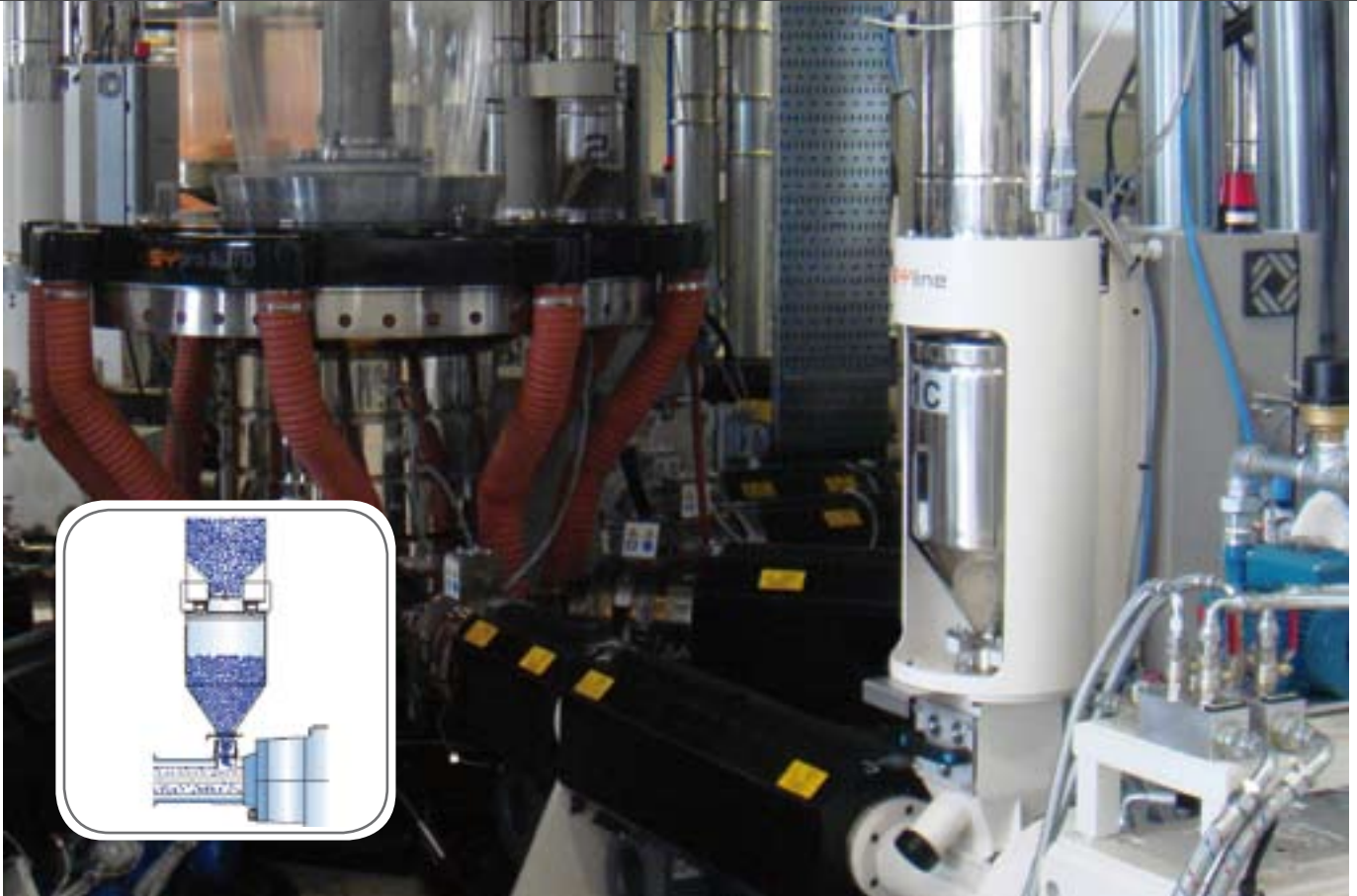

Based on commercial modular PLC  electronics, **SYline** ensures simple, practical operation by providing the operator with all the information required to operate the system clearly and intuitively using touch screen HMI on board.

Process control software **SYline**:

- ☞ Loss in weight control
- ☞ Gram/meter and throughput control
- ☞ Material consumption
- ☞ Alarms

SYNCRO has developed stand alone and centralized conveying system to be automatically integrated into all the SYNCRO blenders Family. Based on commercial modular PLC  electronics, **SYlink** & **SYnet** ensures simple integration along with all SYNCRO machines.





SYNTROLplus is a complete supervisory system designed to control existing or new complete extrusion blown film line. SYNCRO provides complete system PLC based control on either mono or coextrusion blown line **SYNTROLplus** series.



SYNTROLplus SCADA 15" PLC includes:

- ✦ Electrical panels for temperatures and pressure control
- ✦ Electrical panel for power and drives control
- ✦ Air conditioned for cabinet temperature control
- ✦ Control Pulpit for PC Touch Screen "SYNTROL"
- ✦ Temperature control of all heat/cool and heat only zones
- ✦ Speed control of all extruders drivers
- ✦ Blenders and yield control
- ✦ Centralized conveying system and material handling
- ✦ IBC control & Lay flat control
- ✦ IBC % Air Ring blowers control
- ✦ Bubble cage open/close & raise/lower control
- ✦ Open close collapsing frame
- ✦ Gauging system control
- ✦ Automatic air ring or auto die control
- ✦ Oscillating nip left/right control
- ✦ Oscillating nip open/close control
- ✦ Secondary nip open/close control
- ✦ Haul off drives speed control
- ✦ Alignment control
- ✦ Auxiliary equipment control



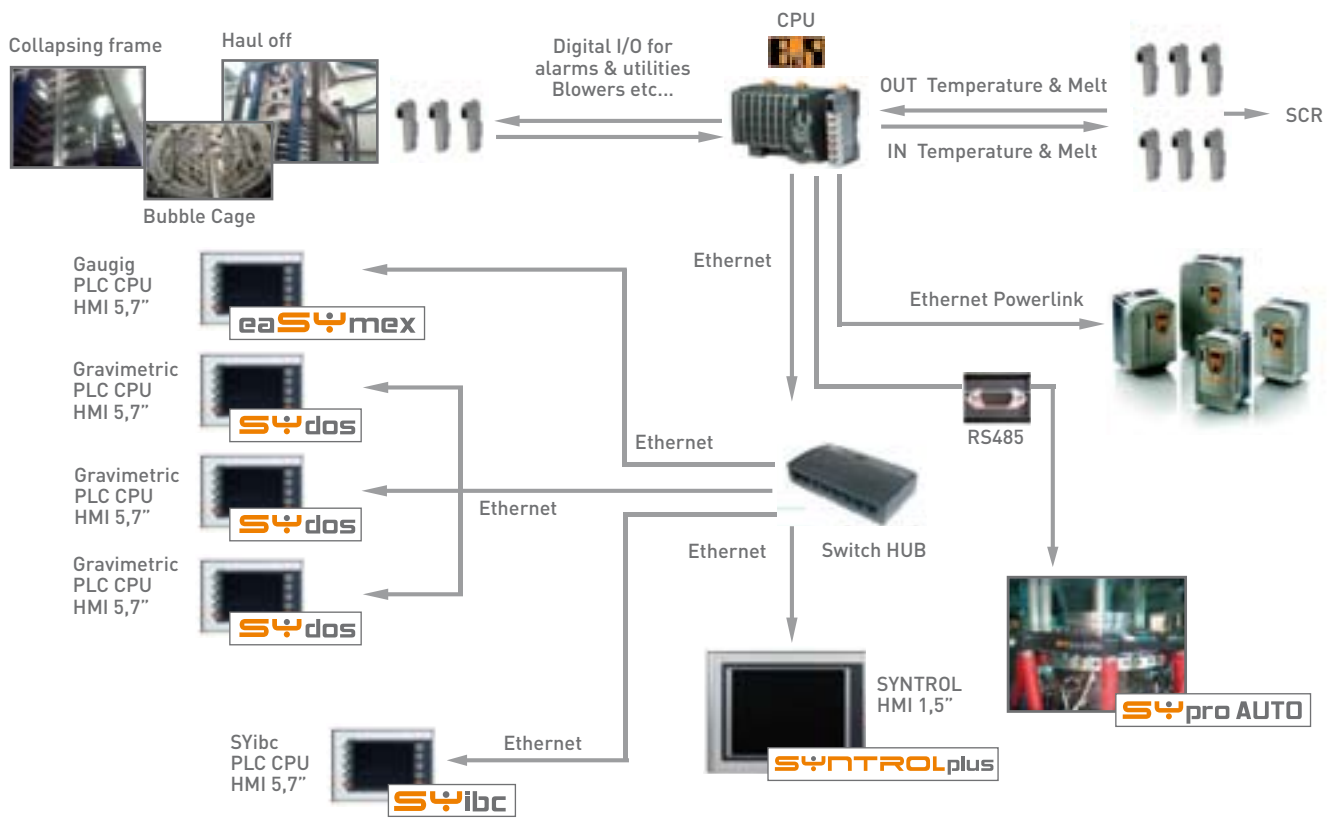

SYNTROLremote is a supervisory system to remotely control all SYNCRO machines via Ethernet to the customers office to allow production management to control the line's production and prepare the following jobs.

Based on commercial modular PLC  electronics, **SYNTROLremote** ensures simple, practical operation by providing the operator with all the information required to operate the system clearly and intuitively using touch screen HMI on board.

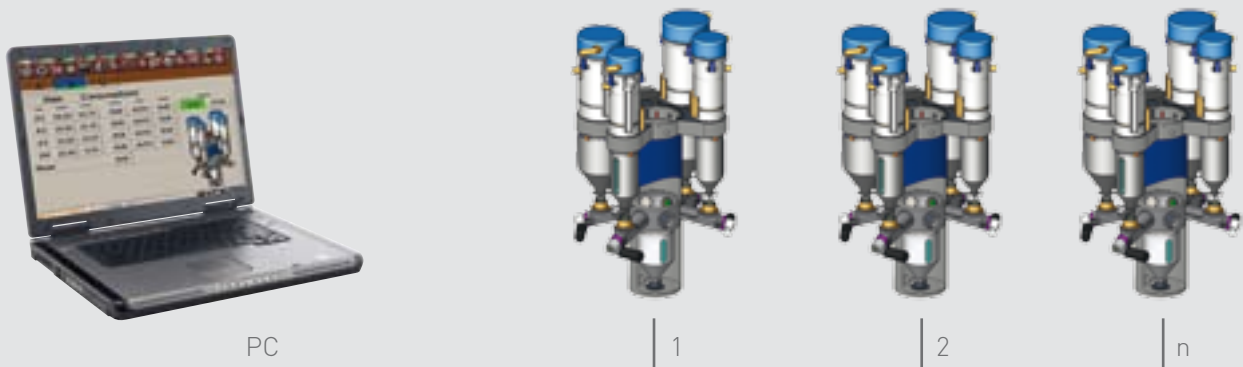



The automatic Rewinder **ecosy** is the status of art of automatic rewinder for the production of Stretch Cling Film for manual and automatic use. The machine is multipurpose being able to produce coreless and conventional paper core reels.



The internal diameter of the reel will be 2" or 3" in both cases. Thanks to the user friendly human interface operator can easily set the production parameters: meters or weight, speed, tension, contact force, taper function, etc. The project, focused on the control of the tension from the first layer up to the end of the reel index included is based on brushless synchronous motors with digital drives and proprietary software managing dedicated functions to set the speed of the motors and monitoring the real web tension by load cells. The machine is prepared to add a pre-stretching unit with special coated rolls and brushless motors.

The patent pending shaft is a mechanical collapsible shaft which is perfectly round when expanded once collapsed the perimeter of the body is reduced of about 10%. **This means: zero tension so that is not required to remove the shaft after winding.**

As option **ecosy** can be equipped with :

- ⚡ Edge reinforcement
- ⚡ Oscillating system
- ⚡ Film break sensor
- ⚡ Finished rolls conveyer
- ⚡ Weight per meter control

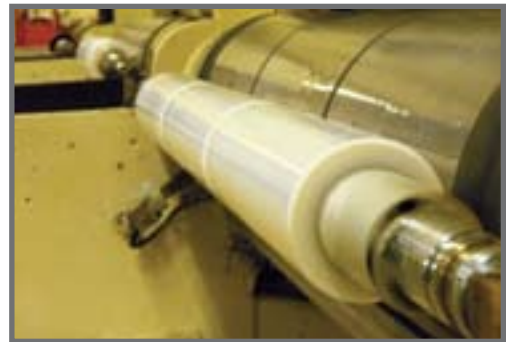

syncro-group.it

