

Industrial **VORTRON** AIRPOWER™



FORCED-AIR CLEANING, DRYING, AND BLOW-OFF JUST GOT BETTER!

Vortron's **AIRPOWER™** line of compact centrifugal blowers promise to raise the bar for industrial blower performance. Flow and pressure not attainable with competitive single stage products are now easily achieved. Three models are available: the flagship Z40, the ultra efficient X40, and the scrappy J70. Each are specialists in their own right and are aerodynamically optimized for meeting specific flow and pressure requirements.

All are clean-sheet designs developed from the ground up to deliver best performance, best durability, and best efficiency available anywhere today. With peak isentropic efficiencies reaching 79%, no other compact blower product even comes close.

Technology A closer look reveals **AIRPOWER™** means business. All products are based upon modern centrifugal compressor design principles with aerodynamic performance vastly superior to common, but outdated technology. Manufacturing and quality are held to aerospace turbomachinery standards, enabling **AIRPOWER™** to consistently meet design performance and efficiency levels well beyond the competition. The elusive 100 in-H₂O at 1,000 SCFM is not only *easily attained*, it's achieved at 75% efficiency!

Development and Test Based upon Vortech's 12-plus years of industry-leading automotive supercharger design, development, and manufacturing, Vortron incorporates the same engineering and development excellence

in the **AIRPOWER™** lineup. A fundamental difference that sets Vortron and **AIRPOWER™** apart is exhaustive testing. Years of analytical and empirical development were devoted to optimizing these designs, with numerous iterations tested and evaluated against stiff criteria. All accomplished with Vortron's gas compressor test stand, developed and operated in accordance with SAE Standard J-1723 – *a first and only in the industry!* As such, Vortron is the only manufacturer which publishes compressor maps, *derived from actual test data*, for all **AIRPOWER™** products.

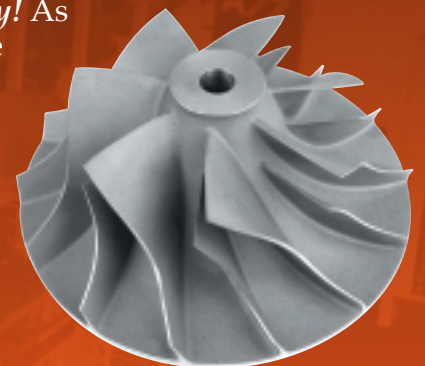

Vortron Means Forced Air Superiority!

Inside AIRPOWER™

It's immediately apparent; **AIRPOWER™** is different by design. Not only does the **AIRPOWER™** compact compressor outperform the competition, a variety of standard features are incorporated which clearly establish an exceptional product.

SPINDLE ASSEMBLY - Take note, **AIRPOWER™** spindles are entirely different from what you're used to seeing. To begin with, the spindle housing is not exposed to the internal *hot* compressed air stream, common with competitive designs. Instead, **AIRPOWER™** incorporates its exclusive Fresh-Aire™ (patent applied for) cooling feature, which supplies an uncompressed *cool air* stream to the bearing housing. This limits temperature rise in the critical bearing and seal elements. Limiting temperature rise in the bearing system has a significant impact on longevity. In general, a 20° increase in running temperature will reduce grease life by a factor of one-half. **AIRPOWER™**'s higher compressor efficiency limits temperature rise even more. The bearing system uses precision (ABEC 9) angular contact (A/C) bearings, with a duplex pair positioned outboard to support the belt load. A/C bearings are better suited for high-speed use and generate less friction, hence less heat and lower temperature rise than competitive deep groove ball bearing designs. The result: greater margin for speed and load capacity, meaning *enhanced durability and extended life*.

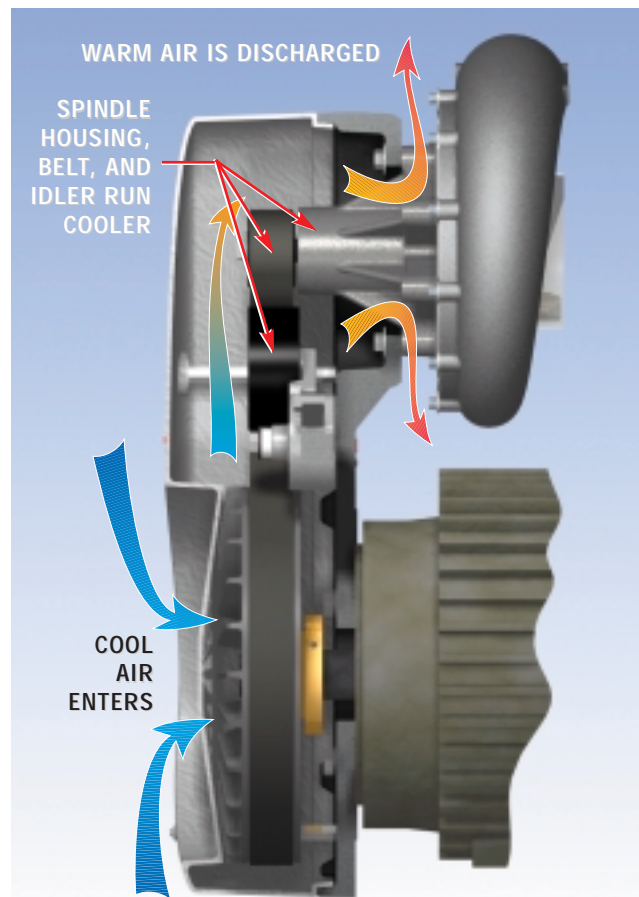

The Fresh-Aire™ System (Patent Applied For)

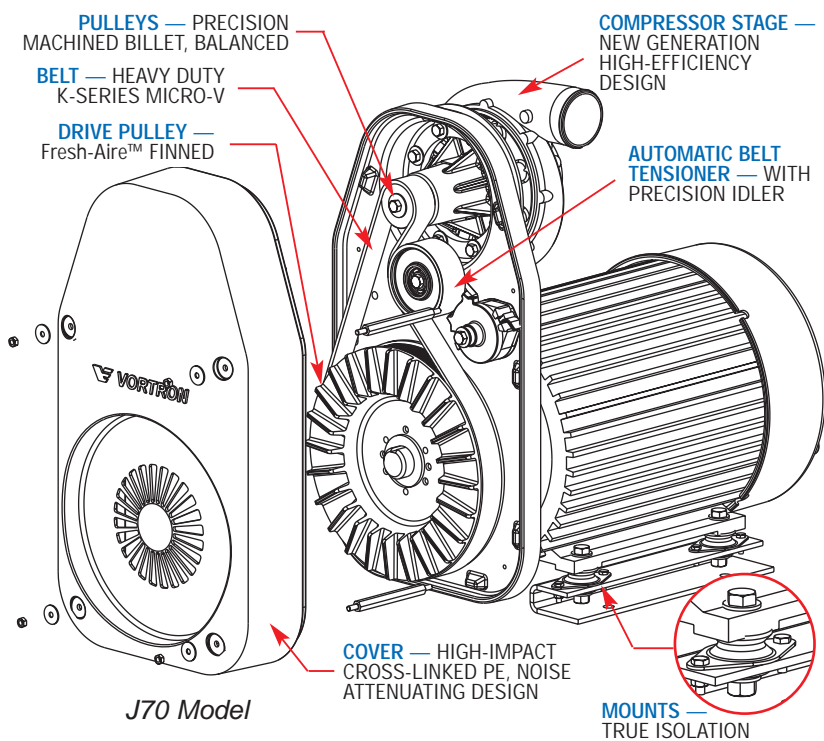

AIRPOWER™ — Standard Features

TENSIONING AND BELT LIFE - Automatic tensioning systems are now seen as standard, but **AIRPOWER™** incorporates a precision machined idler system with dual (proprietary) bearings for extended life. The entire drive system is fully enclosed and cooled by the Fresh-Aire™ system. Reasoning is simple: in general, an 18° temperature rise in the belt can also cut belt life in half! By carrying away heat, temperature rise in the belt and idler system is managed; again, reliability and life are maximized. Customers place a high priority on belt and idler performance – Vortron has engineered a solution!

PRECISION DRIVE SYSTEM COMPONENTS - Designed and manufactured entirely by Vortron, our precision drive components add another level of quality and sophistication to the **AIRPOWER™** product line. Blower pulleys are machined from billet stainless steel and balanced to ISO G4 tolerances. Also part of the Fresh-Aire™ sys-

tem, the unique drive pulley with integral cooling fins is cast aluminum, hard anodized, and balanced. This system makes sense as the large aluminum pulley offers additional capacity to conduct and carry away heat from the drive belt.

CAST MOUNTING PLATE AND COVER - Our customers continue to press for not only enhanced performance and greater reliability, but also quieter operation. A tough bill because making pressure quietly is not easy. But, Vortron ingenuity does it again. The rugged cast mounting plate and cover offer not only exceptional fit and finish to the product, but also effectively manage noise sources.

ADVANCED COMPRESSOR STAGE - Here's where the rubber meets the road! **AIRPOWER™** blower/compressor stages are highly evolved, thoroughly tested designs, originating from years of experience and thousands of production supercharger units. A simple visual examination clearly shows the difference. All **AIRPOWER™** compressors incorporate sophisticated impeller designs, coupled to either a channel or vaneless diffuser with a progressive scroll, or volute exit stage. Impellers incorporate advanced aerodynamic features such as optimized inducer blading, splitters, and in some cases, exit rake and backsweep... all depending on the particular pressure/flow objectives. Rather than a simple change of blower speed to effect different "models"



Z40, 20HP Model

each **AIRPOWER™** model is optimized aerodynamically so that the best performance is attained for your specific application.

In order to effectively take advantage of impeller work, flow must be efficiently diffused so that pressure can be generated with minimal losses. Exclusive to **AIRPOWER™**, diffusers are incorporated, each optimally matched to the impeller flow physics, with many iterations tested and verified until maximum efficiency is achieved. Finally, a matched volute effectively collects and diffuses further, resulting in additional pressure rise.

The result? Isentropic efficiencies as high as 79%! In fact, all **AIRPOWER™** compressors achieve at least 76% peak efficiency, with better than 70% efficiency over a majority of design flow range (surge to choke). Note that these same efficiency levels are achieved at discharge pressures which clearly eclipse the competition for a low-cost, single-stage machine. The **AIRPOWER™** Z40 for example, is capable of 170" H₂O pressure at 1,300 SCFM, and 72% efficiency! Looking at it another way, a 20HP Z40 easily delivers the elusive 100" H₂O at 1,000 SCFM.

IT ALL ADDS UP TO:

More performance; enhanced durability; reduced energy consumption and reduced annual operating costs. In other words, *improved bottom line.*

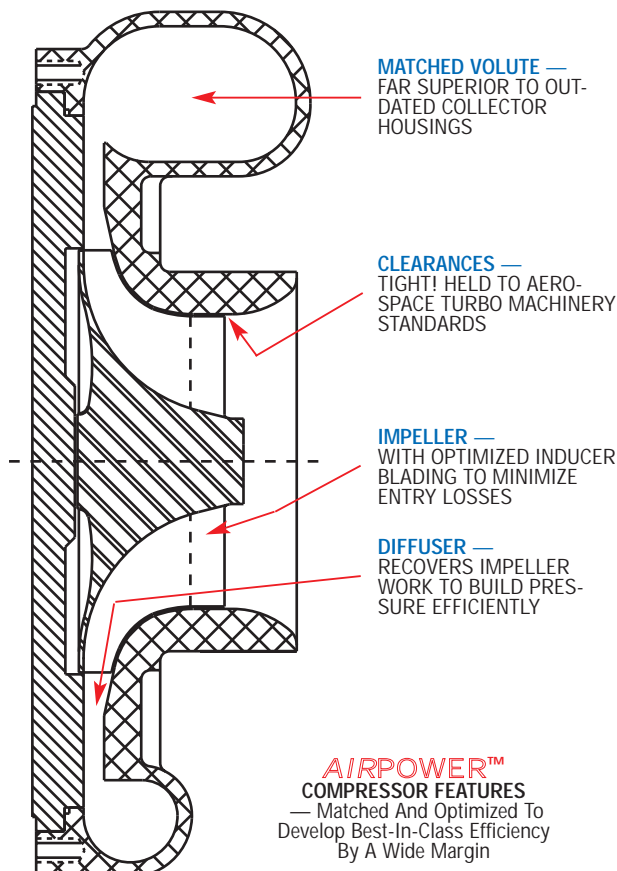

The Players

Z40

The flagship of Vortron's AIRPOWER™ series. Where flows of 600 to 1600 SCFM at pressures at or above 70 in-H₂O are required, the Z40 surpasses all others! This model exhibits an extraordinarily

flat flow/pressure characteristic that is notably absent of the typical "drooping" curve. In some cases, this enables a single Z40 to do the work of multiple units. 77% peak efficiency is attained. Ideal for ultra high-performance air knives, high volume blow-off, and de-watering applications typical with canning, beverage, and electronic industries. Also, air evacuation, aeration, large fluidized beds; air or non-corrosive process gas.

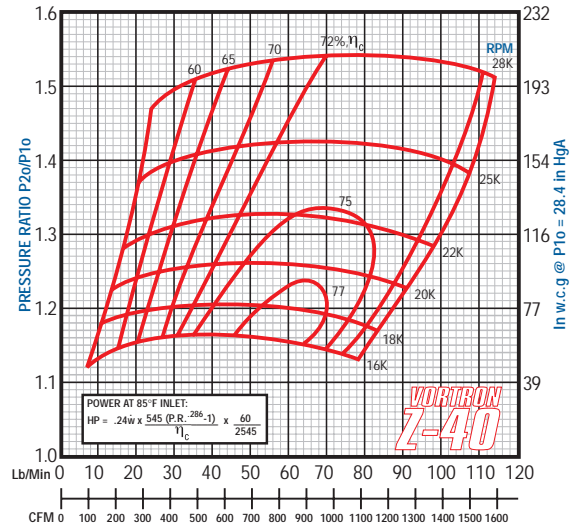

J70

Vortron's most compact AIRPOWER™ model. The J70 specializes in the lower flow, but higher pressure applications without need for excessive impeller

speeds. Still, the J70 attains a peak efficiency of 76%! Ideal for high-performance air knives, blow-off, or de-watering systems where high production throughput is required, but manufactured articles are smaller in scale. Also ideal for medium-sized fluidized beds or where large pressure drop/long piping runs exist. Use with air or non-corrosive gas.

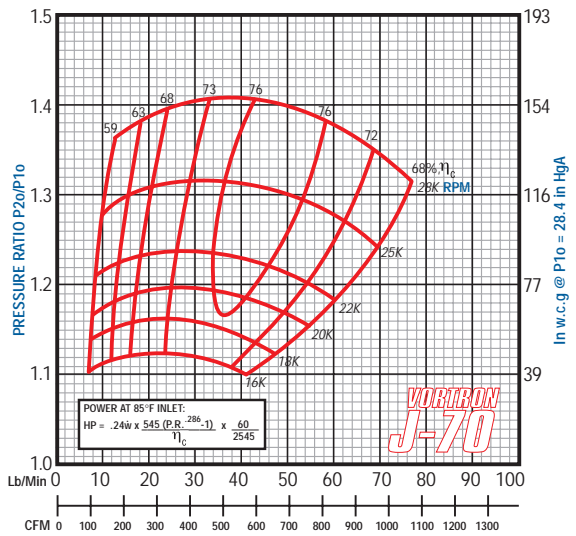

X40

Vortron's highest efficiency AIRPOWER™ model. Perfect for intermediate flow applications at moderate pressure where the ultimate in energy efficiency is desired. At 79% peak

efficiency, the X40 outclasses all others by a wide margin! The best choice where high duty or extended "on time" impresses the need for energy conservation. Applications include high-performance air knives, blow-off, or de-watering nozzles used in compact, high-throughput process cleaners; air evacuation, aeration, fluidized beds; air or non-corrosive process gas.

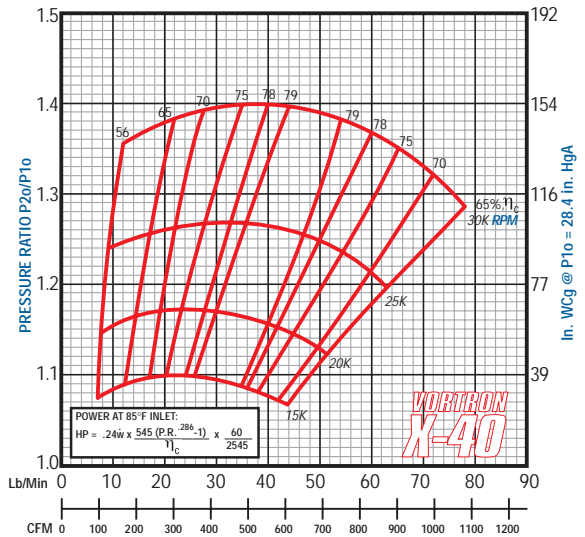

INDUSTRIAL
 A Division Of Vortech Engineering, LLC
 ProdFlyr030602-2 -- 04/03/02 - V1.0

805.247.0226

1650 Pacific Avenue, Channel Islands CA 93033-9901 • Fax: 805.247.0669

www.vortron.com